

Wi-Fi Communicating Thermostat

- New All-in-One Design
- Wi-Fi Enabled Thermostat – iPhone / iPad Compatible
- Compatible with Wi-Fi Networks – Easy Set Up
- Thermostat Control Program Software Included
- Standard or Heat Pump HVAC Systems
- 128x64 Backlit Graphical Display
- 6 Buttons with On Screen Labels
- Remote Control of Thermostat Functions
- Optional Remote Sensors
- Wall mount or mounts on single-gang junction box



Overview

The TW45 is a Wi-Fi enabled wireless digital thermostat, designed to control HVAC systems. The TW45 contains a robust thermostat interface and is designed for use with networked systems where remote monitoring and/or remote control are desired.

Thermostat Features

- Local temperature display on a backlit LCD
- Set point display and control
- System Mode (Off, Auto Changeover, Heat, Cool)
- Fan Mode display and control (Auto, Manual On)
- On-screen setup of HVAC Type, Fan Type, Change over type for Heat Pump systems, and sensor calibration - On-screen Wi-Fi Network set up
- Degrees Fahrenheit or Celsius Modes
- Compatible with the majority of HVAC systems

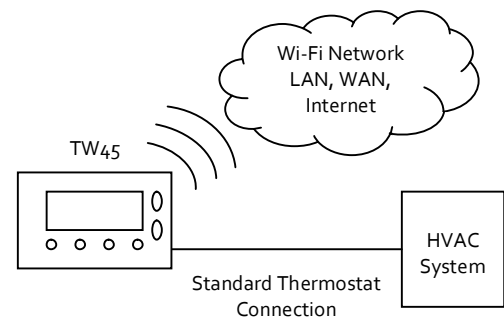

Technical Specifications

HVAC System Compatibility

- Central HVAC systems or separate heating/cooling systems; can use separate RH/RC transformers (split)
- Standard gas/electric HVAC Systems: 2-stage heating, 2-stage cooling
- Heat Pump HVAC Systems: 3-stage heating, 2-stage cooling
- Fan system: Selectable for gas or electric heat systems
- Heat Pump Change Over valve (reversing valve): Selectable for change over with heat or change over with cool
- Emergency Heat: In Heat pump mode, Emergency Heat mode is directly selectable from the thermostat
- Compressor short cycle protection delay – Adjustable
- Automatic heating and cooling changeover
- Fan Cycler feature

Remote Sensors

- The TW45 supports up to 2 remote sensors: 1 - Indoor and 1 - Outdoor
- Indoor remote sensor can replace internal sensor or provide averaging
- Compatible with Flush Mount Remote Temperature Sensor (RTS3)

Wiring Requirements

- 18 AWG
- Uses standard thermostat connections (C, R, W1, W2, Y1, Y2, G)

Power Requirements

- 24VAC **Note: Requires both R and C wires from the HVAC System**

Dimensions

- 5"x3"x3/4"

Model Number

- TW45 Wi-Fi Thermostat 001-01727